



Aliva-272 Concrete Spraying Pump WITH ACCELERATOR TANK

■ The compact Concrete Spraying Pump

The almost pulsation free operating Aliva-272 has been developed specially for sprayed concrete. For this reason it is equipped with a synchronized Aliva-403.6 dosing unit. The Aliva-272 control system regulates the accelerator pump output proportionally according to the concrete output. The Aliva-272 is particularly suitable for sprayed concrete with steel fibers.

■ Easy handling, maintenance and cleaning

At the Aliva-272 the concrete output is shown on a display and can be regulated continuously either on the control box or on the remote control. The hood that opens completely, the hinged hopper and the optimized set-up of the components simplify service and maintenance. The pump can also run backwards for pressure relief of the pumping line and for cleaning.

■ Usage as a powerful Concrete Pump

Additionally, the Aliva-272 can also be used for pure pumping of concrete with gravel up to 32 mm. With a maximum conveying pressure of 80 bar there is enough power to reach a working distance up to 300 m efficiently.

Aliva-272

Concrete Spraying Pump

The Aliva-272 is a powerful and compact double piston pump with S-tube for sprayed concrete as well as conveying of concrete. It comes with an integrated, synchronized dosing unit for the accelerator. The Diesel and electric versions are available on forklift suitable skids or on a two axles trailer with a 1000L accelerator tank. The control display makes it easy to monitor the outputs of the concrete pump and dosing unit.

YOUR ADDED VALUE

- Integrated, synchronized dosing unit for accelerators
- Output regulation at the control box or at the remote control
- Maximum conveying distance of 300 m (80 bars conveying pressure)
- Maximum grain size 32 mm (pumped concrete)
- Easy handling with crane or forklift
- Reduced wear due to optimized cylinder dimensions
- Low pulsation

STANDARD EQUIPMENT

- Agitator
- Electric vibrator
- Grid for steel fibers and rubber collar
- Air manifold with electromagnetic valve
- Aliva-403.6 dosing unit for accelerator
- Set of reductions DN125-DN65/180°
- 1000 liter accelerator tank
- lifting points

DIMENSIONS

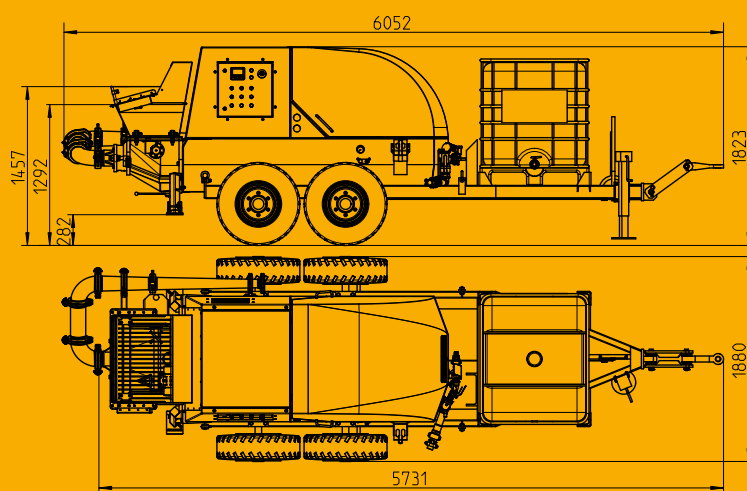

VERSIONS

- Diesel or electric
- Skid or trailer

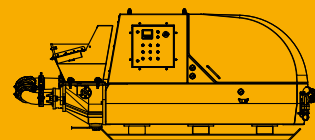

OPTIONAL

- Hydraulic high pressure cleaner
- Cable or radio remote control
- Particle filter (Diesel)
- Original accessories such as spraying device, pumping hoses and couplings from the Aliva Converto dense stream catalogue

TECHNICAL DATA

Concrete pump	
Type	Electric / Diesel
Weight	2'200 kg
Theoretical output	3 - 20 m ³ /h
Stroke	12.4 liter
Max. grain size: spraying/pumping	16 / 32 mm
Max. conveying distance*	300m
Concrete pressure	max. 80 bar
Interior Ø pump outlet	125mm
Coupling size	5.5"
Air consumption (shotcrete)	10.5 Nm ³
Required air pressure (shotcrete)	~7 bar
Electric drive	
Voltage / Frequency	3 x 400-480 V 50/60 Hz
Power	37 kW
Current in A	~ 80 A
Diesel drive	
Motor	Deutz 3 cylinder
Power	34.5 kW / 47 PS
Emission standard	EU Stufe IIIA/US EPA Tier 3
Dosing unit AL-403.6 Synchro	
Type	Squeeze pump
Output pressure	max. 10 bar
Viscosity	max. 200 mPas
Output	30-700 liter/h
Suction hose with lance	DN25 / 6m

* Depends on various factors; Aliva suggests the use of steel pipes over 80 m conveying distance with the Aliva-272 and the use of INOX steel pipes over 60 m conveying distance with the Aliva-403.

Prior to use or processing, always consult the current operating manual of the products used. The current version of our respective General Terms and Conditions applies.

NORMET INTERNATIONAL LIMITED

Aliva Equipment
Bellikonerstrasse 218
CH-8967 Widen
Switzerland

Contact

Phone +41 58 436 32 22
www.aliva-equipment.com
aliva.equipment@normet.com

normet **aliva**